



ANDRE



PRÜGIKAST

Andre

Prügikast ANDRE 120/65 on mahukas ja praktiline lahendus linnaruumi. Prügikasti on võimalik tellida koos tuhatoosiga või ilma. Kõik detailid on kuumtsingitud ja pulbervärvitud, et tagada toote kauakestev vastupidavus.

Roostevaba terasest (AISI 304) konimahuti on eraldatud muust prügist ja on lihtsasti tühjendatav. Baltimaades toodetud prügikasti puhul on arvestatud ka kasutusmugavust talvistes tingimustes kus sokli kõrgus on piisav. Mahukas 120-liitrine väliprügikast on vedrulukuga lukustatav uks. Innovaatiliseks lahenduseks on vihmavett juhtiv prügikasti kaas.

ANDRE-seeria väliprügikasti saab tellida laias valikus RAL-värvitoonides. Lai värvivalik võimaldab sobitada prügikasti ümbritseva hoonestiku või keskkonna värvitoonides.

TOOTEKOOD: ATK120, ATK65

Bränd: Dambis

Möödud

ATK120

Kõrgus: 1036 mm
Laius: 368 mm
Pikkus: 583 mm
Mahutavus: 120 liitrit
Kaal: 50 kg
Materjali paksus 2,5 mm

ATK65

Kõrgus: 870 mm
Laius: 368 mm
Pikkus: 385 mm
Mahutavus: 65 liitrit
Kaal: 37 kg
Materjali paksus 2,5 mm

Lisavõimalused

Lukustatav hingedega ühepoolne uks;
Kotihoidja või sisemine tsingitud ämber;
Tuhatoosiga/ilma

Kinnitusviis

Ankrutega valatud
pinnasele

Värvivalik



RAL
9007



RAL
9005



RAL
3020



RAL
7024



RAL
1028



RAL
7016



RAL
6005

Metall



Kuumtsingitud ja
pulbervärvitud





Andre

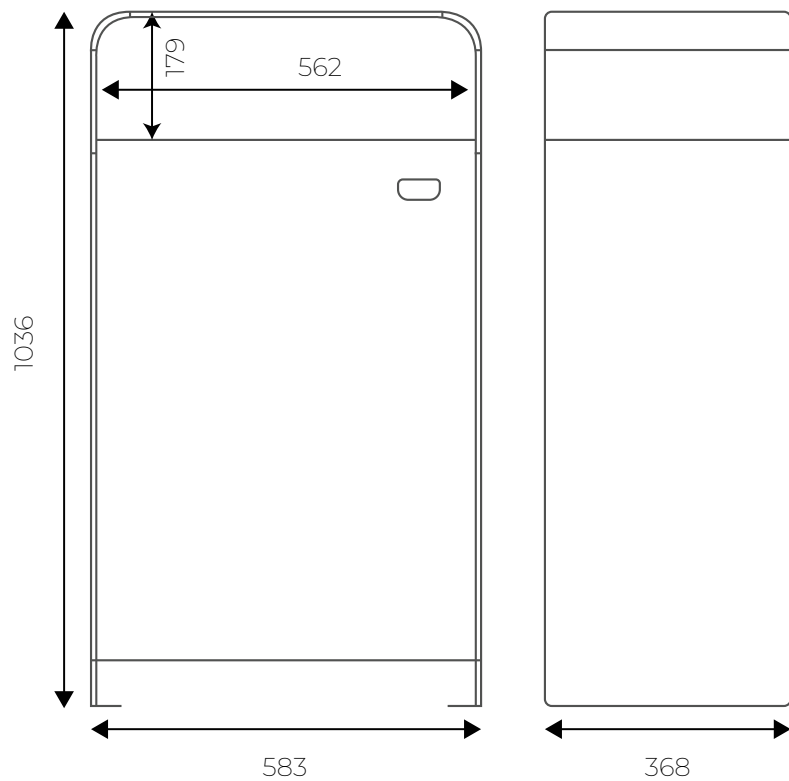

ATK120

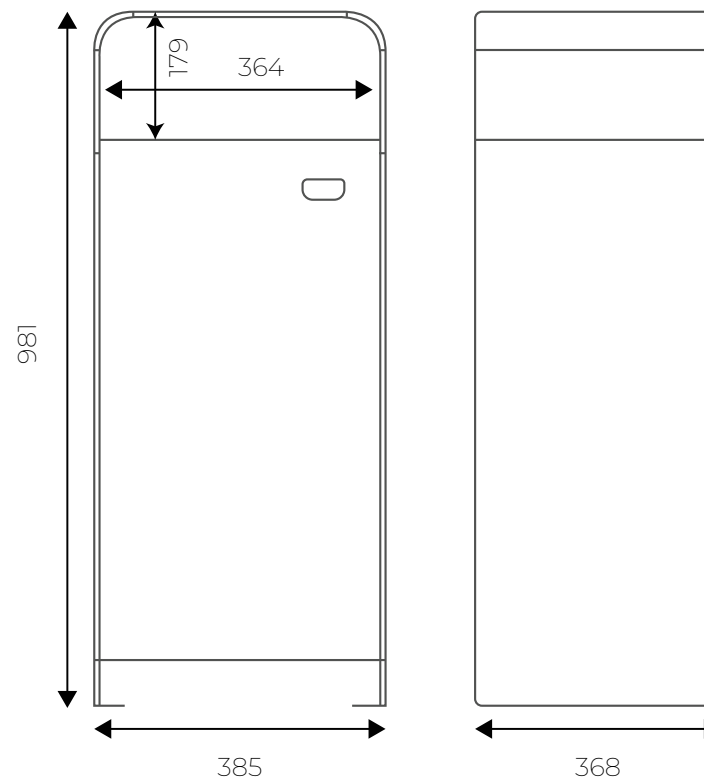

ATK65



PRÜGIKAST

Andre

ENGLISH // Litter bin Andre

The litter bin Andre 120/65 is a practical and solid solution in any environment. The upper part of the litter bin has an ashtray and the lower part has a litter bin bag container.

Ease of use is created by the large capacity of the ANDRE 120 model, a separate garbage bag and a door that can be locked with a spring lock.

An innovative solution is a lid that conducts rainwater. The ANDRE series litter bins can be ordered in all RAL colors. A wide range of colors allows you to match the bins with the colors of the surrounding buildings or environment.

ANDRE 120 is manufactured from galvanized steel. The litter bins are coated with polyester powder paints that are resistant to UV radiation, rain, snow and salt. High quality and resistance to climatic conditions are confirmed by international certificates.

Measurements:

ANDRE120

Height: 1036 mm
Width: 368 mm
Length: 583 mm
Capacity: 120 liters
Weight: 50 kg
Material thickness 2.5 mm

ANDRE65

Height: 870 mm
Width: 368 mm
Length: 385 mm
Capacity: 65 liters
Weight: 37 kg

Standard equipment:

Lockable hinged one-sided door;
Bag holder or inner galvanized bucket;
With/without ashtray;

Installation methods:

Can be attached to a strong base

Additional Accessories:

Available in all RAL-colours